

PMX™

PROMAXIMA

www.PMXSTRENGTH.com



WEIGHT ROOM EQUIPMENT CATALOG

STRENGTH FROM WITHIN.

AMERICAN MADE 

\$1.00



STRENGTH FROM WITHIN.

TABLE OF CONTENT	1
PMX-RACKS	2
PMX-RACKS : UNIVERSAL ACCESSORIES	10
POWER RACKS	12
CABLE WALL UNITS	20
FLOORING	22
CUSTOM RIGS	26
EQUALIZER	29
ABDOMINAL & BACK	30
LOWER BODY	31
UTILITY BENCHES	32
BODY TRAINING EQUIPMENT	34
WEIGHT BARS	35
BUMPER PLATES	36
WEIGHTS	38
WEIGHT RACKS	39
WEIGHT STORAGE	40
MED BALLS & ABDOMINAL	42
PLYOMETRICS & ACCESSORIES	43
PLATE LOADED	44
STEALTH SERIES	47
RAPTOR SERIES	48
SELECTORIZED	50
CABLE MACHINES	52
MULTI-GYMS	55
CARDIO MACHINES	56
EQUIPMENT CUSTOMIZATION	63
COLOR CHART : UPHOLSTERY COLORS	64
COLOR CHART : POWDER COAT COLORS	65



PMX4307-HR
Half Rack

- 4x3 Notched Upright
- 7 Gauge Steel
- 3 Way Urethane Chinup
- (2) 7 Gauge Laser Cut Sleeves
- (2) Bar Hooks
- (2) 28" Safety Arms
- (2) Bar Storage
- (4) Universal Band Pegs
- (10) Weight Peg Storage



PMX4307-FR
Full Rack

- 4x3 Notched Upright
- 7 Gauge Steel
- 3 Way Urethane Chinup
- (4) 7 Gauge Laser Cut Sleeves
- (2) Bar Hooks
- (2) Safety Crash Arms
- (2) Bar Storage
- (4) Universal Band Pegs
- (10) Weight Peg Storage



PMX4307-DHR
Double Half Rack

- 4x3 Notched Upright
- 7 Gauge Steel
- (2) 3 Way Urethane Chinup
- (4) 7 Gauge Laser Cut Sleeves
- (4) Bar Hooks
- (4) 28" Safety Arms
- (4) Bar Storage
- (8) Universal Band Pegs
- (12) Weight Peg Storage

Accessories



PL-820D
Dip Station



PL-885
Single Leg Squat



PL-8314
Safety Arm Pair



PL-400-8
J-Hook (Left)

PL-400-11
J-Hook (Right)



PMX4307-FH
Full Half Rack

- 4x3 Notched Upright
- 7 Gauge Steel
- (2) 3 Way Urethane Chinup
- (6) 7 Gauge Laser Cut Sleeves
- (4) Bar Hooks
- (2) Safety Crash Arms
- (2) 28" Safety Arms
- (4) Bar Storage
- (8) Universal Band Pegs
- (12) Weight Peg Storage



PMX4307-DFR
Double Full Rack

- 4x3 Notched Upright
- 7 Gauge Steel
- (2) 3 Way Urethane Chinup
- (8) 7 Gauge Laser Cut Sleeves
- (4) Bar Hooks
- (4) Safety Crash Arms
- (4) Bar Storage
- (8) Universal Band Pegs
- (12) Weight Peg Storage

Accessories



PL-820D
Dip Station



PL-885
Single Leg Squat



PL-8314
Safety Arm Pair



PL-400-8
J-Hook (Left)

PL-400-11
J-Hook (Right)



PMX3311-HR
Half Rack

- 3x3 Universal Upright
- 11 Gauge Steel
- 3 Way Urethane Chinup
- (2) Bar Hooks
- (2) 28" Safety Arms
- (2) Bar Storage
- (4) Universal Band Pegs
- (10) Weight Peg Storage



PMX3311-FR
Full Rack

- 3x3 Universal Upright
- 11 Gauge Steel
- 3 Way Urethane Chinup
- (2) Bar Hooks
- (2) Safety Crash Arms
- (2) Bar Storage
- (4) Universal Band Pegs
- (10) Weight Peg Storage

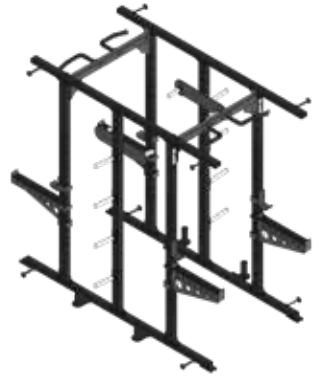

PMX3311-DHR
Double Half Rack

- 3x3 Universal Upright
- 11 Gauge Steel
- (2) 3 Way Urethane Chinup
- (4) Bar Hooks
- (4) 28" Safety Arms
- (4) Bar Storage
- (8) Universal Band Pegs
- (12) Weight Peg Storage

Accessories



SP-220
Dip Station



SP-385
Single Leg Squat



UHS-34
Safety Arm



SP-640APE3X3
Hook

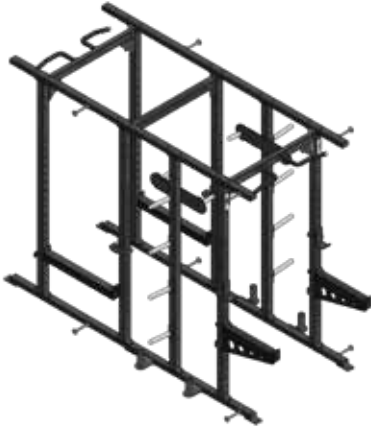

PMX3311-FH
Full Half Rack

- 3x3 Universal Upright
- 11 Gauge Steel
- (2) 3 Way Urethane Chinup
- (4) Bar Hooks
- (2) Safety Crash Arms
- (2) 28" Safety Arms
- (4) Bar Storage
- (8) Universal Band Pegs
- (12) Weight Peg Storage

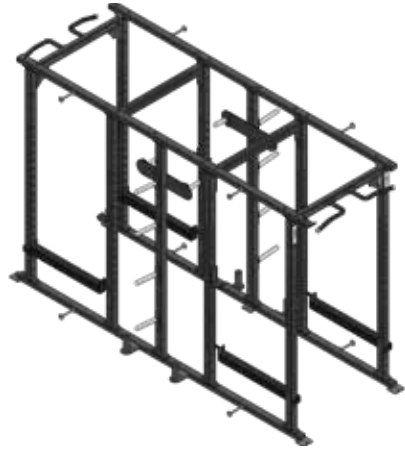

PMX3311-DFR
Double Full Rack

- 3x3 Universal Upright
- 11 Gauge Steel
- (2) 3 Way Urethane Chinup
- (4) Bar Hooks
- (4) Safety Crash Arms
- (4) Bar Storage
- (8) Universal Band Pegs
- (12) Weight Peg Storage

Accessories



SP-220
Dip Station



SP-385
Single Leg Squat



UHS-34
Safety Arm



SP-640APE3X3
Hook

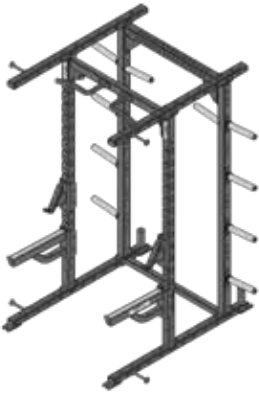

PMX3307-HR
Half Rack

- 3x3 Dual Notched Upright
- 7 Gauge Steel
- 3 Way Urethane Chinup
- (2) Bar Hooks
- (2) 28" Safety Arms
- (2) Bar Storage
- (4) Universal Band Pegs
- (10) Weight Peg Storage



PMX3307-FR
Full Rack

- 3x3 Dual Notched Upright
- 7 Gauge Steel
- 3 Way Urethane Chinup
- (2) Bar Hooks
- (2) Safety Crash Arms
- (2) Bar Storage
- (4) Universal Band Pegs
- (10) Weight Peg Storage

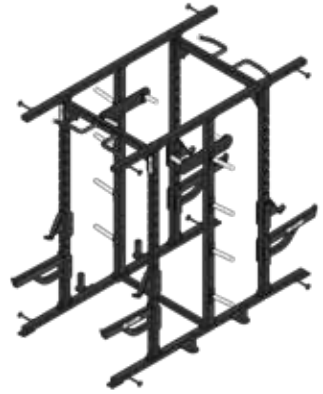

PMX3307-DHR
Double Half Rack

- 3x3 Dual Notched Upright
- 7 Gauge Steel
- (2) 3 Way Urethane Chinup
- (4) Bar Hooks
- (4) 28" Safety Arms
- (4) Bar Storage
- (8) Universal Band Pegs
- (12) Weight Peg Storage

Accessories



PL-220D
Dip Station



PL-385
Single Leg Squat



PL-502-N19
Safety Arm



PL-501-N19
Hook

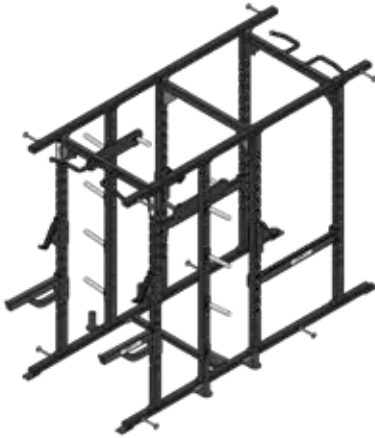

PMX3307-FH
Full Half Rack

- 3x3 Dual Notched Upright
- 7 Gauge Steel
- (2) 3 Way Urethane Chinup
- (4) Bar Hooks
- (2) Safety Crash Arms
- (2) 28" Safety Arms
- (4) Bar Storage
- (8) Universal Band Pegs
- (12) Weight Peg Storage

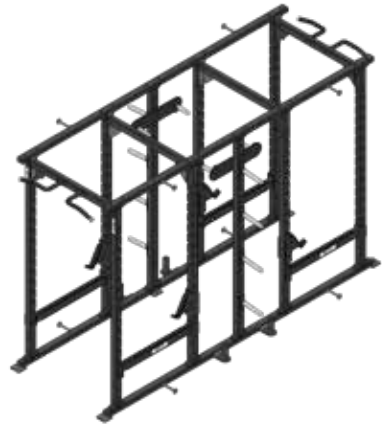

PMX3307-DFR
Double Full Rack

- 3x3 Dual Notched Upright
- 7 Gauge Steel
- (2) 3 Way Urethane Chinup
- (4) Bar Hooks
- (4) Safety Crash Arms
- (4) Bar Storage
- (8) Universal Band Pegs
- (12) Weight Peg Storage

Accessories



PL-220D
Dip Station



PL-385
Single Leg Squat



PL-502-N19
Safety Arm



PL-501-N19
Hook



PMX3211-HR
Half Rack

- 3x2 Universal Upright
- 11 Gauge Steel
- 3 Way Urethane Chinup
- (2) Bar Hooks
- (2) 28" Safety Arms
- (2) Bar Storage
- (4) Universal Band Pegs
- (10) Weight Peg Storage



PMX3211-FR
Full Rack

- 3x2 Universal Upright
- 11 Gauge Steel
- 3 Way Urethane Chinup
- (2) Bar Hooks
- (2) Safety Crash Arms
- (2) Bar Storage
- (4) Universal Band Pegs
- (10) Weight Peg Storage

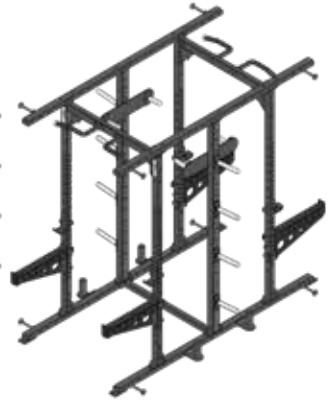

PMX3211-DHR
Double Half Rack

- 3x2 Universal Upright
- 11 Gauge Steel
- (2) 3 Way Urethane Chinup
- (4) Bar Hooks
- (4) 28" Safety Arms
- (4) Bar Storage
- (8) Universal Band Pegs
- (12) Weight Peg Storage

Accessories



SP-220
Dip Station



SP-385
Single Leg Squat



SP-640APE2X3
Safety Arm



SP-640APE2X3
Hook

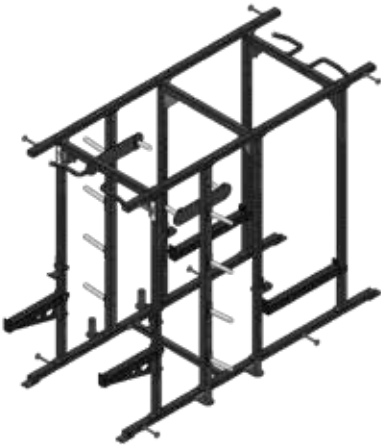

PMX3211-FH
Full Half Rack

- 3x2 Universal Upright
- 11 Gauge Steel
- (2) 3 Way Urethane Chinup
- (4) Bar Hooks
- (2) Safety Crash Arms
- (2) 28" Safety Arms
- (4) Bar Storage
- (8) Universal Band Pegs
- (12) Weight Peg Storage

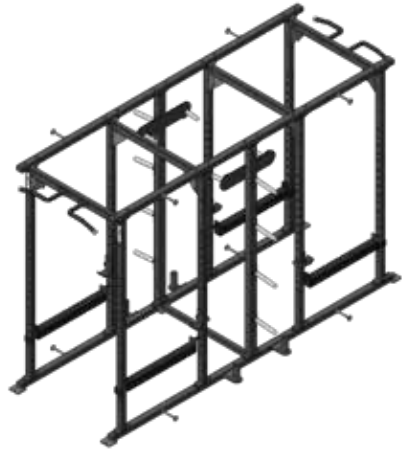

PMX3211-DFR
Double Full Rack

- 3x2 Universal Upright
- 11 Gauge Steel
- (2) 3 Way Urethane Chinup
- (4) Bar Hooks
- (4) Safety Crash Arms
- (4) Bar Storage
- (8) Universal Band Pegs
- (12) Weight Peg Storage

Accessories



SP-220
Dip Station



SP-385
Single Leg Squat



SP-640APE2X3
Safety Arm



SP-640APE2X3
Hook



PMX-PA

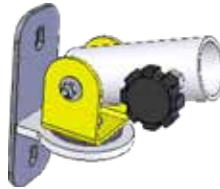

50423
Land Mine



PMX-BA
Band Attachments



SP-647-C
Storage Shelves

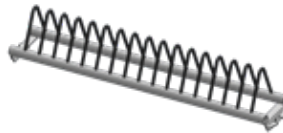

SP-646
Bumper Storage

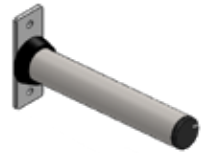

OLYPHOLDER3



PL-803
Bar Storage



PMX-HBS-1
Single Hanging
Bar Storage



PMX-HBS-1
Double Hanging
Bar Storage



TA-100
Triphasic Arms



PL-319
Connecting Cross Member
with logo bridge



PL-318
Connecting
Cross-Member



PL-618
Bridge with logo



SP-617
Connecting Cross-Member



PMX-HL
HIGH LAT/LOW ROW
225lbs Weight Stack



PL-317
Connecting
Cross-Member



PL-820

Deluxe Double Sided Half Rack

- 3" x 4" 7 Gauge Steel Uprights
- 7 Gauge Laser Single Upright Sleeves
- Weight Plate and Bumper Plate Storage
- Optional Laser Cut Logo
- Bar Storage
- (4) Safety catch arms
- (4) J-hooks
- Variable Grip Chin-up station
- Landline Attachment

OPTIONS

- Flip Down Spotter Stands
- Cannonball Chin-Up Grips
- Rope Pull Down
- D-Ring for Undulation
- Single Leg Squat Stand
- Technique Trays
- Removable Glute and Ham Developer
- Bumper Plate Tray
- Dip Station
- Power Arms
- Step-up Platform



PL-830

Deluxe Double Sided Full & Half Rack

- 3" x 4" 7 Gauge Steel Uprights
- 7 Gauge Laser Single Upright Sleeves
- Weight Plate and Bumper Plate Storage
- Optional Laser Cut Logo
- Bar Storage
- (4) Safety catch arms
- (4) J-hooks
- Variable Grip Chin-up station
- Landline Attachment

OPTIONS

- Flip Down Spotter Stands
- Cannonball Chin-Up Grips
- Rope Pull Down
- D-Ring for Undulation
- Single Leg Squat Stand
- Technique Trays
- Removable Glute and Ham Developer
- Bumper Plate Tray
- Dip Station
- Power Arms
- Step-up Platform

Racks Shown with Options.



PL-840
Deluxe Half Rack



PL-865
Deluxe Full Power Rack

- 3" x 4" 7 Gauge Steel Uprights
- 7 Gauge Laser Single Notched Chrome or Powder Coated Upright Sleeves
- Weight Plate and Bumper Plate Storage
- Optional Laser Cut Logo
- Bar Storage
- (2) Safety catch arms
- (2) J-hooks
- Variable Grip Chin-up station
- Landline Attachment

OPTIONS

- Flip Down Spotter Stands
- Cannonball Chin-Up Grips
- Rope Pull Down
- D-Ring for Undulation
- Single Leg Squat Stand
- Technique Trays
- Removable Glute and Ham Developer
- Bumper Plate Tray
- Dip Station
- Power Arms
- Step-up Platform

- 3" x 4" 7 Gauge Steel Uprights
- 7 Gauge Laser Single Upright Sleeves
- Weight Plate and Bumper Plate Storage
- Optional Laser Cut Logo
- Bar Storage
- (2) Safety catch arms
- (2) J-hooks
- Variable Grip Chin-up station
- Landline Attachment

OPTIONS

- Flip Down Spotter Stands
- Cannonball Chin-Up Grips
- Rope Pull Down
- D-Ring for Undulation
- Single Leg Squat Stand
- Technique Trays
- Removable Glute and Ham Developer
- Bumper Plate Tray
- Dip Station
- Step-up Platform

Racks Shown with Options.



SP-600 Sport Series
Double Sided Half Rack

- 3" x 3" 7 gauge multi hole upright posts
- Adjustment holes are 2" on center
- Laser engraved numbering for exact bar positioning
- 4 – Adjustable J-hooks
- 4 – Adjustable bar catches
- Weight and bar storage
- Chin up station
- 3 – Stage durable powder coat finish



SP-640 Sport Series
Half Rack

- 3" x 3" 7 gauge multi hole upright posts
- Adjustment holes are 2" on center
- Laser engraved numbering for exact bar positioning
- 2 – Adjustable J-hooks
- 2 – Adjustable bar catches
- Weight and bar storage
- Chin up station
- 3 – Stage durable powder coat finish

Racks Shown with Options.



SP-645
Modular Half Rack System

- 3" x 3" 7 gauge multi hole upright posts
- Adjustment holes are 2" on center
- Laser engraved numbering for exact bar positioning
- Adjustable J-hooks
- Adjustable bar catches
- Adjustable Weight and bar storage
- Chin up station
- 3 – Stage durable powder coat finish



SP-670 Sport Series
Full Rack

- 3" x 3" 7 gauge multi hole upright posts
- Adjustment holes are 2" on center
- Laser engraved numbering for exact bar positioning
- 2 – Adjustable J-hooks
- 2 – Adjustable bar catches
- Weight and bar storage
- Chin up station
- 3 – Stage durable powder coat finish

Racks Shown with Options.



PRO PL-320
Double Sided Half Rack



PL-310 W/ Oak Platform



PRO PL-370
Full Power Rack



PL-360 Full Power Rack



PRO PL-340
Half Rack



Pro PL-350 W/ Oak Platform



PL-547

Collegiate Double Sided Half Rack

- 3" x 4" 7 Gauge double laser notched uprights w/laser engraved numbering system for exact bar location.
- 4 – Stainless steel heavy duty lock-on weight bar catches.
- 4 – Stainless steel heavy duty lock-on adjustable safety catch arms.
- Weight plate/bumper plate storage w/open top rack for easy access.
- 2 – Vertical weight bar holders
- 3 – Stage durable powder coat finish additional cost



PL-102

Smith Machine



PLR-950

7 Degree Angled Smith Machine w/Linear Bearings. 1" Case Hardened Steel Guide Rods and weight storage

PLR-955 - Also Available Angled Smith Machine w/ Linear Bearings. 2" shafts and weight storage

CF-9300 Outlaw Rack System



Features

- 3" x 3" 7 Gauge steel frame.
- Angled front rack protects athletes/ users knees during heavy squat or bench lifting.
- Numbered adjustment system.
- 2 – Adjustable safety catches w/ protective coating.
- Double rack, Smith Machine combo.
- Foot plates for rowing exercises.
- Chin up station.
- Lat pull down/Low row with 225 lb. solid steel weight stack.
- Bright red colored pull knobs.
- Weight plate and bar storage.
- 1/4" nylon coated aircraft cable driven, 4800 lb. test
- Hundreds of exercise variations.
- Powder coat finish.
- Accessory storage.
- Unit height 95"
- Chin up station requires at least a 9' ceiling

CF-9500 Outlaw Rack System



Features

- 3" x 3" 7 Gauge steel frame.
- Angled front rack protects athletes/ users knees during heavy squat or bench lifting.
- Numbered adjustment system.
- 2 – Adjustable safety catches w/ protective coating.
- Single Rack, Smith Machine, Dual Adjustable Pulley Combo.
- Foot plates for rowing exercises.
- Chin up station.
- Lat pull down/Low row with 225 lb. solid steel weight stack.
- Dual Adjustable Pulley with (2) 225 lbs Solid Steel Weight Stacks
- Bright red colored pull knobs.
- Weight plate and bar storage.
- 1/4" nylon coated aircraft cable driven. 4800 lb. test
- Hundreds of exercise variations.
- Powder coat finish.
- Accessory storage.
- Unit height 95"
- Chin up station requires at least a 9' ceiling

CW-2 Cable Wall Units



Specifications

- Single Stacks X 2
- Flat Shelves X 3
- D rings on X 2 (on each cross connector)
- 225lb Weight Stack X 2

Attachments Included

- Rope X 1
- V- grip X 2
- Short T-Handle X 1

CW-4 Cable Wall Units



Specifications

- Single Stacks X 4
- Flat Shelves X 9
- D rings on X 2 (on each cross connector)
- 225lb Weight Stack X 4

Attachments Included

- Rope X 2
- V- grip X 4
- Short T-Handle X 2



1.25" x 2' x 2' Shock Absorbing Flooring with Inlaid Platforms



Pope High School - Marietta, GA

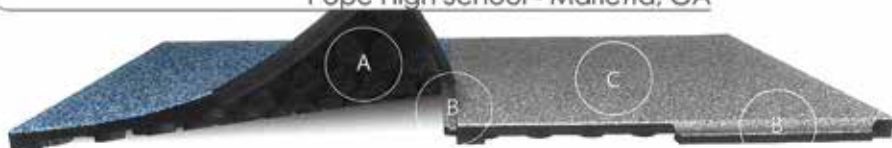

Colors

Midnight Black



Slate Gray



A. HOLLOW CORE PEDESTAL DESIGN

- Raise the system off the floor creating plenty of air space for superior cushioning effect
- Absorbs both sound and vibration
- Allow cables to be channeled through the underside of the product
- Evenly distributes fitness equipment weight over 64 pedestals per tile



B. OMNI-DIRECTIONAL LOCKING DESIGN

- Locks the system firmly in place without the use of adhesive
- Non-shifting and non-separating
- Simple, and efficient to install
- Can be picked up and relocated or reconfigured to harmonize with any design or layout changes to your facility

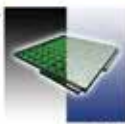

C. HIGH COMPRESSION WEAR LAYER

- ASTM Compliant for slip resistance
- Fire resistant (premium series)
- Tested for over 400,000 repeated impacts with an 800 pound blunt force
- Available in a virtually unlimited number of custom color combinations

Shock Absorbent Rubber Flooring



Paetow High School - Katy, TX

8mm, 9mm or 14.5mm rolled gym flooring available.
Also available with optional custom inlaid logos.

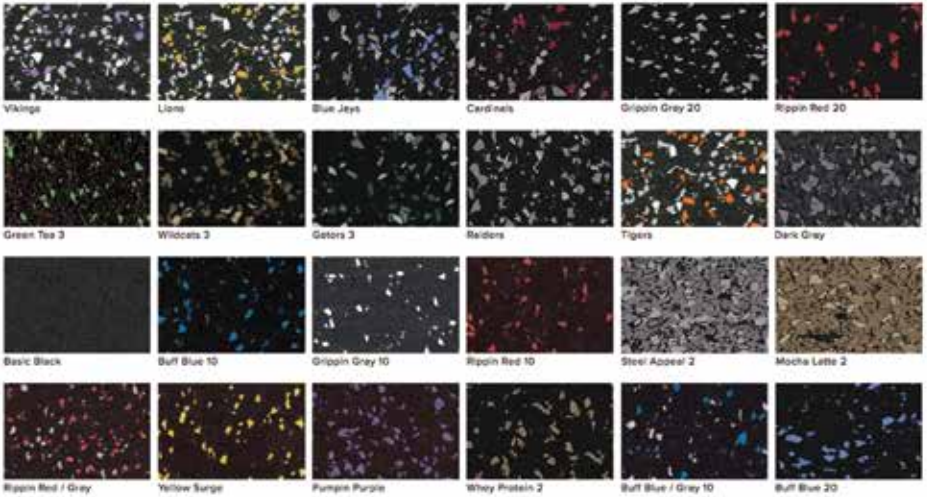

Rolled Rubber Flooring

1" x 2' x 2' High Density Shock and Sound Absorbent Tile



Available Colors

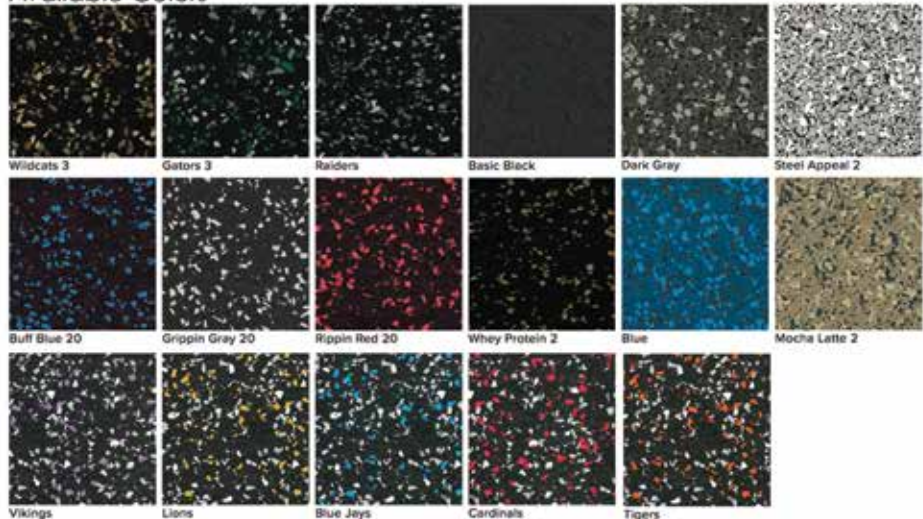

UltraTile Fitness Flooring

MAW2313

Shok-Lok Power Flooring



Easy to Install.
Anti-Slip.
Scuff Resistant.
Resists Spills and Stains
Loose Lay Product, No Adhesive
Necessary.
Will not Curl or Separate.
Insulates Against the Cold.
Virtually Maintenance Free.
Absolutely Non-Absorbent.
LokTuff Precision Water Jet Cut
Eliminates Gaps.
Will Not Harbor or Promote
Bacterial Growth.
Minigation Agent Added to Reduce
Rubber Smell.



Available Size: 7'6" x 6'

Rubber Mats

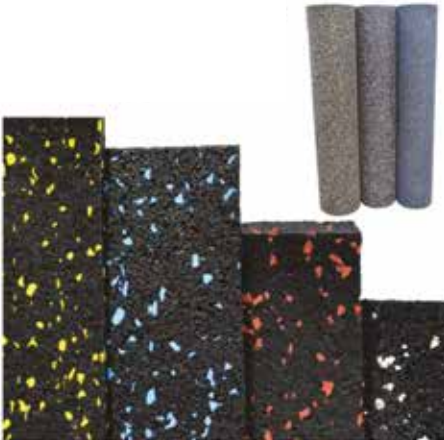

Available in 8mm or 9mm thickness

4'x6' and 4'x8' mats
available in 1/2" and
3/4" thickness.

Build it the way you want!



Customized Rigs to Meet Your Spatial Requirements

Rig Attachments

50417	REBOUNDER	HEAVY BAG	50423	50436
PL-385	LEG CURL	DIP STATION	BALL TARGET	

Call For Custom Pricing

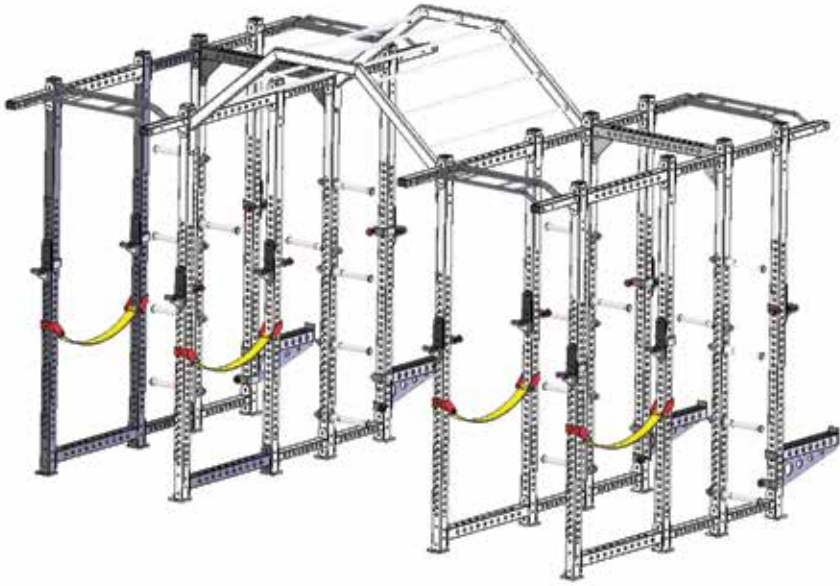

*Maximize Your Space With A
Custom Rack Designed By You*



Call For Custom Pricing

NEW Panther Rig

- Ⓐ D-Ring
- Ⓑ Monkey Bars
- Ⓒ Standing Leg Curl
- Ⓓ Accessory Shelves
- Ⓔ Smith Machine
- Ⓕ Ball Rebounder
- Ⓖ Pull-up Bar
- Ⓗ Plate Holders
- Ⓘ Rope Cleat
- Ⓝ Heavy Bag
- Ⓚ Landmine
- Ⓛ Suspension Attachment



NEW Multi-purpose / Sectional Training and Storage Rack

Holds:
Dumbbells,
Kettlebells,
Med Balls
and all other
Accessories

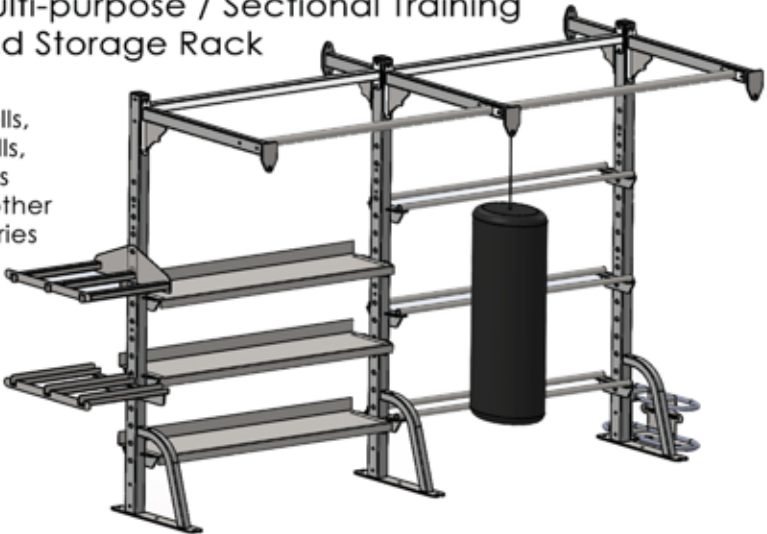

Call For Custom Pricing



Equalizer 3

- 3" x 4" 7 Gauge steel frame.
- Multiple users at the same time.
- 4 Configurations to choose from.
- Maximize workout w/minimal space.
- Large selection of attachments available.
- Weight ball and Kettlebell storage.
- Durable powder coat.

OPTIONS

- Heavy bag attachment.
- Step-up platform.
- Dip attachment.
- Sit up foot holder.
- Landmine.
- Ball rebounder.
- Chin-up station.
- Center rope attachment.
- Rope cleats.

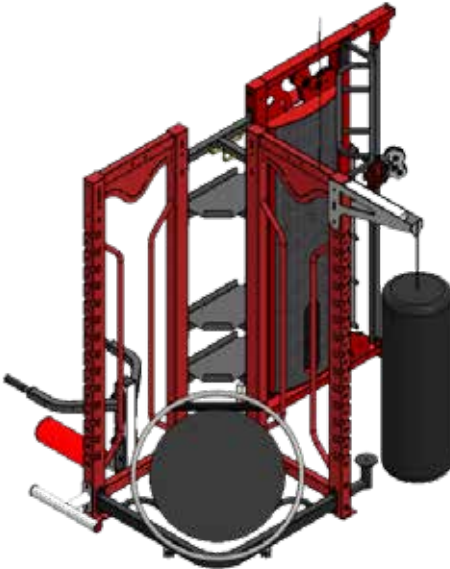

Equalizer 8

- 3" x 4" 7 Gauge steel frame.
- Multiple users at the same time.
- 4 Configurations to choose from.
- Maximize workout w/minimal space.
- Large selection of attachments available.
- Weight ball and Kettlebell storage.
- Durable powder coat.

OPTIONS

- Heavy bag attachment.
- Step-up platform.
- Dip attachment.
- Sit up foot holder.
- Landmine.
- Ball rebounder.
- Chin-up station.
- Center rope attachment.
- Rope cleats.

Call For Custom Pricing



PL-204
Combo Glute & Ham
Back Extension

Glute & Ham Developers



PLR-776
Glute & Ham

Glute & Ham Developers



PLR-750
Back Extension

Abdominal & Back



RPL-38
Belt Squat



P-44A
Power Runner

Lower Body



PL-156B
3-Way Hip & Leg Sled



P-118
Inverted Leg Press

Lower Body

FW-150U

Adjustable Workbench w/ wheels

Bench stands upright for better storage



Adjustable from 0-90°

FW-166

Adjustable Workbench w/ wheels



PL-610

Multi Adjustable Workbench w/ Wheels



Adjustable from Decline to Incline

PL-128U

Deluxe Adjustable Bench w/ Spotter Stand



Adjustable from 0-90°



PLR-600

Flat Work Bench w/Wheels



PLR-800

Seated Utility Bench



FW-36

Squat Stool



FW-66

Shoulder Press Stool w/ Reversible Seat



PLR-487
Single Dip Stand



PLR-488
Double Dip Stand

Dip Stands

BAROLYCURL
Olympic Power Curl Bar



FW-48
9-Bar Holder



BAROLYFB
7' Football Bar



FW-44
10-Bar Holder



Promaxima Trap Bar



BAROLYTRAPST



OLYTRAPBAR

Also available as rackable trap bars with extended weight horn shafts.

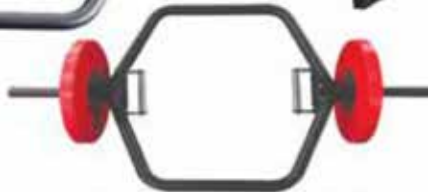

ACFT-TRAP Trap Bar

PROMAXIMA trap bars accommodate small and large framed athletes.

Weight Bars and Storage

BAROLY2000CCK

2000 lb. Chrome Needle Bearing Bar with Center knurling



BAROLY2000CW/O

2000 lb. Chrome Needle Bearing Bar without center knurling

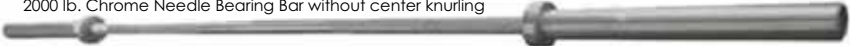

BAROLY2500BW/CK

2500 lb. Black Olympic Bar w/ Center Knurling



BAROLY2500BW/O

2500 lb. Black Olympic Bar w/o Center Knurling



BAROLY1500B

1500 lb. Black Olympic Bar



BAROLYJRHIGH

6' Jr. High Olymic Bar



BAROLY6

6' 17lb. Aluma-Lite Bar



BAROLYSQUAT

Squat Bar - BAROLYSQUAT



BAROLYSQUAT2

Squat Bar - BAROLYSQUAT2



OLYSQUATBAR

Squat Bar - OLYSQUAT



Weight Bars

Standard Color Bumper Plates

BUM-45LB



45lb.

BUM-35LB



35lb.

BUM-25LB



25lb.

Competition Color Power Bumper

11213



45lb.

11212



35lb.

11211



25lb.

Standard Black Bumper Plates

BUMHI-45LB

BUMHI-35LB

BUMHI-25LB

BUMHI-15LB

BUMHI-10LB



45lb.

35lb.

25lb.

15lb.

10lb.

Competition Black Power Bumper

11217

11216

11215



45lb.

35lb.

25lb.



EZR-45
Rubber Encased Grip Plates

- EZR-02.5
- EZR-05
- EZR-10
- EZR-25
- EZR-35

Olympic Plates



KETTLE BPRO 005
Rubber Encased Kettlebells

- | | | |
|-----------------|-----------------|-----------------|
| KETTLE BPRO 005 | KETTLE BPRO 035 | KETTLE BPRO 065 |
| KETTLE BPRO 010 | KETTLE BPRO 040 | KETTLE BPRO 070 |
| KETTLE BPRO 015 | KETTLE BPRO 045 | KETTLE BPRO 075 |
| KETTLE BPRO 020 | KETTLE BPRO 050 | KETTLE BPRO 080 |
| KETTLE BPRO 025 | KETTLE BPRO 055 | KETTLE BPRO 085 |
| KETTLE BPRO 030 | KETTLE BPRO 060 | |

Kettlebells



HEXR-045
Rubber Encased Hex Dumbbells

- | | | |
|----------|----------|----------|
| HEXR-005 | HEXR-040 | HEXR-075 |
| HEXR-010 | HEXR-045 | HEXR-080 |
| HEXR-015 | HEXR-050 | HEXR-085 |
| HEXR-020 | HEXR-055 | HEXR-090 |
| HEXR-025 | HEXR-060 | HEXR-095 |
| HEXR-030 | HEXR-065 | HEXR-100 |
| HEXR-035 | HEXR-070 | |



URD-SET1
Urethane Dumbbells

- | | |
|----------|---------|
| URD-SET1 | URD-125 |
| URD-SET2 | URD-130 |
| URD-SET3 | URD-135 |
| URD-105 | URD-140 |
| URD-110 | URD-145 |
| URD-115 | URD-150 |
| URD-120 | |

Dumbbells

FW-275L
2-Tier 4' Kettlebell Rack



FW-276
3-Tier 4' Kettlebell Rack
(Not Shown)

FW-277
3-Tier 8'
Kettlebell Rack



Kettlebell Racks

FW-234L
2-Tier 5' Dumbbell Rack



FW-233L
3-Tier 5'
Dumbbell Rack



Dumbbell Racks

PLR-500 (Shown)
2-Tier Dumbbell
Rack with Saddles



9' Long

PLR-500A
without saddles

Dumbbell Racks

Kettlebells and Dumbbells Sold Separately

PLR-504

3-Tier 15 Pair
Dumbbell Rack
w/ Saddles

11' Long

Holds 21 pairs of
Dumbbells



FW-69

Barbell Rack

Holds 10 Barbells either
straight or curled.

Barbell sets available in Rubber.
Straight or Curled. 20 – 110lbs set
in 10lb. increments



BB-RESSET

Rubber Barbells : Rubber Encasted
Straight set. 20 – 110lbs

BB-RECSET

Rubber Barbells : Rubber Encasted
Curl set. 20 – 110lbs



FW-76
Plate Rack w/ Wheels



FW-139L
Horizontal Bumper
& Plate Rack



FW-3
Rolling
Bumper
Plate
Storage



Horizontal Plate Holders



FW-152
Deluxe
Weight
Holder



FW-205
Vertical Bumper
Plate Holder

FW-13
Olympic
Plate Holder



Vertical Plate Holders

STR
Mobile
Storage
Rack



STR-15
Accessory
Rack



Weight Storage Racks

SB-15

Slam Balls



- SB-04
- SB-08
- SB-10
- SB-12
- SB-15
- SB-18
- SB-20
- SB-25
- SB-30
- SB-35
- SB-40
- SB-45
- SB-50

11086

Soft Medicine Balls 18lb



- 11082 - 10lb
- 11083 - 12lb
- 11084 - 14lb
- 11085 - 16lb
- 11086 - 18lb
- 11087 - 20lb
- 11088 - 30lb

MB-020

Hard Medicine Balls



- MB-006
- MB-008
- MB-010
- MB-012
- MB-015
- MB-018
- MB-020



FW-103L
Medicine
Ball Rack

Medicine Ball Racks



FW-47
Stackable Metal
Plyometric Boxes

Also available
in 12" & 6"



11233
Wood Plyometric Boxes
12", 18", 20", 24" & 30"

11129
3 in 1 Foam
Plyometric Box
20" x 24" x 30"



Foam Plyometric Boxes



- 11119
- 11120
- 11121
- 11122
- 11123

Plyometric Boxes



FW-1012-D
Plow Sled w/
Removable Handles



FW-1014
Mini Speed Sled



Quick
Release
Harness

FW-77
Belt Rack w/ Wheels



(Belts Also Available)



PSP
Power Sled w/ Handle

CT-100
Undulation
Rope Anchor
Station



AC-CR2NROPE50

Black Nylon Ropes
Rope Diameters:
1.5" or 2" grip.
Rope Lengths:
30', 40', & 50'



AC-STROOPS77

Stroops Ropes
Resistance Levels:
77lb, 105lb, 150lb.

AC-G

**Spring Loaded
Weight Collars**
AC-GRIZZLYGRIP



**Grizzly
Weight Collars**
AC-LOCKJAWFS



**Steel Composite
Lock Jaw Pro
Weight Collars**



Workout Accessories



FW-21
Standing
T-Bar Row



FW-18
T-Bar Row

Upper Body

PLR-450
Preacher Curl



FW-4
Hi Lat/ Low Row

Upper Body

FW-33
4-Way Neck
Machine



FW-89
Combo Leg Curl/
Leg Extension



Auxillary Units



RPL-12
Vertical Chest
Press



RPL-7
Tricep Press

Upper Body



RPL-76
Hi Lat Pull



RPL-43
Unilateral
Tricep

Upper Body

RPL-45
Seated Thigh Extension



RPL-46
Prone Leg Curl

Lower Body



PL-62
Unilateral
Seated
High Row



PL-54
Dual Chest
Lat Pull

Upper Body

PL-39
Vertical Chest Press



PL-15
Unilateral
Hamstring Curl



PL-30
Unilateral
Power Lunge

PL-52
Reversible
Squat



Lower Body





P-4100
Hi Lat Pull



Upper Body



Upper Body



Lower Body

P-4400
Weight
Assisted
Chin-Up/
Dip



P-3350
Combo
Seated
Arm Curl



P-4300
Hi Lat Pull/
Seated
Row



P-1350
Multi Chest
Press



P-5500
Dual Leg
Extension/
Leg Curl



P-5800
Combo Leg
Extension/
Prone Leg
Curl



P-6300
Combo
Adduction/
Abduction



P-6550
Abdominal/
Back
Extension





STEALTH SERIES

Features

- Premium Performance
- True Cam Resistance
- Fully Enclosed Weight Shroud
- Instructional Placard
- Water Bottle Holder
- 2" x 4" Oval 11 Gauge Tubing
- Small Footprint
- 5lb. Add-on weight system

Selectorized



Neutral and Wide grip chin-up

P-7200
Adjustable Cable Crossover

Includes 2 Patented Trak Handles

Selectorized

Small Footprint. Big Results.
Unbeatable Value.

PMX's Raptor strength series will fit your fitness facility without breaking a sweat...or you budget.

Range-of-Motion & Limiter

Allows exact alignment for starting and ending positions of any size athlete, which is a necessity for proper biomechanics and rehabilitation work.



Cam Engineered Variable Resistance

1/4" thick solid steel cams, computer-designed and laser-cut to exact spec to allow proper variable resistance throughout the complete range of motion.



Pulley Wheels

5" and 6" reinforced solid web fiberglass body with a 1/2" cable groove. Oil-dipped, double-sealed racer ball bearings with 1/2" axis shaft hole. Sealed for moisture and dust-proof. 1/4" thick steel pulley housing welded directly to frame.



Friction-Free Bearings

Pivot points use double-sealed Radial Bearings with steel housings and a 1-inch axis steel shaft used for maximum strength.



Cable System

1/4" thick, 4800 lb. military spec galvanized and oil-impregnated aircraft cable, finished with a thick nylon coating. Manual Tension Adjusters for cable adjustments.

5 lb Weight Kit

Allows increase of resistance by 5 lb increments.

Frame

Constructed of high stress 2" x 4", 2" x 3" & 2" x 2" ASTM A-500 Grade B structural carbon steel tubing (11 @ 7- Gauge). All welds are ground down and stress-tested.

Instructional Guide

Color charts display correct usage for each machine along with anatomical highlights to showing focus muscle groups.



Weight Stack

Adjusted with a tethered, magnetic selector pin.



Weight Shroud

Weight stacks are completely enclosed in full-length shrouds.



Finish

Magnetic powder coating process results in a flawless, uniform finish.



Protective Cover

ABS Seat and Back protective dishes.

Upholstery

40 oz. commercial grade

Commercial Warranty

LIFETIME

Frames, Welds and/or Weld Allowance, Weight Stacks, & Plates

5 YEARS

Friction Free Bearings, CAMS, Guide Rods, & Bushings

2 YEARS

Power Bumper Plates On Olympic Lifting Platform (Minimum 1" Thick) or Crash Pad (Minimum 10.5 MM Thick) Thickness Required

1 YEAR

Cables, Pulley Wheels, Upholstery, Pop Pins, Weight Stack Selector Pins, Dumbbells, Kettlebells, Barbells, Olympic Plates, Foam Plyo Boxes, EZR Oly Plates, Standard Bumpers & Bum Hi Plates

90 Days

All ABS Plastics On Strength Equipment, Polyurethane / Neoprene Rollers



Build it your way

CM-704

4 Station Multi-Gym (Shown w/
2 Hi Lats & 2 Cable Columns)

Available Stations



CM-720 - High Lat Pull
w/ Single Pulley
CM-721 - High Lat Pull
w/ Dual Pulley



CM-722 - Combo
High Lat Pull/
Seated Row



CM-725 - Row Station
w/ Single Pulley
CM-726 - Row Station
w/ Dual Pulley



CM-730 - Adjustable
Pulley Station



CM-740 - Adjustable
Pulley Station w/ Leg
Supports



CM-745 -
Tricep Press
Station



CM-746 -
Tricep Push
Down Station



CM-750 -
Leg Press



CM-760 -
Combo Leg
Extension/Prone
Leg Curl



CM-770 - Combo
Chest Press

CM-705
5 Station Multi-Gym



CM-708
8 Station Multi-Gym





CM-335

Multi Functional Trainer

- Dual adjustable pulley system with 2 enclosed weight stacks.
- 11 different pulley adjustments on each column.
- Multiple people can work out at one time.
- Includes multi-grip chin up station.
- Over 40 Exercises.
- Patented Trak-Handles



CM-337

Functional Trainer Corner Unit

- Dual adjustable pulley system with 2 enclosed weight stacks.
- 11 different pulley adjustments on each column.
- Multiple people can work out at one time.
- Includes multi-grip chin up station, lat pull, low row and over 40 Exercises.
- Corner unit designed to maximize limited space.
- Patented Trak-Handles

P-350

3 Station Multi-Gym



- 2" x 2" and 2" x 3" 11 Gauge steel construction.
- 40 oz. Seamless upholstery, bacteria free.
- Leg extension/ leg curl/ chest press/ incline press/ shoulder press.
- Seated low row.
- High lat pull w/ padded seat and thigh pads.
- Knee raise/ dip station.



P-130B-3

Butterfly Attachment Available

Multi-Gyms

P-235

4 Stack Multi Gym



- 2" x 2" and 2" x 3" 11 Gauge steel construction.
- 40 oz. Seamless upholstery, bacteria free.
- Leg press.
- Chest press/ incline press/ shoulder press
- High lat pull down/ seated low row.
- Leg extension/ leg curl.

Multi-Gyms

CV-GT5 Commercial Treadmill



Features

- Speed rating from 0.2 to 13.2 mph
- Incline rating from 0 to 15%
- 4.2 HP AC Brushless Motor
- Over 20 Programs
- Contact Heart-Rate Receivers
- Personal Adjustable Fan
- 60" L x 22" W Running Surface
- 1" Reversible Phenolic Deck
- Premium 4-Ply Orthopedic Running Belt
- Cushioned Deck System Absorbs Impact
- 3" Belt Roller
- 6.75" Step On Height
- Emergency Stop Safety Tether
- USB Charging Port
- Dedicated 110V/20 amp c
- 20-Amp Dedicated & Separated Circuit From Breaker Box
- Nema 3 Prong Plug
- 450 lbs max user weight

CV-GE5

Commercial Elliptical

Features

- Self powered drive system
- Multi-grip handles
- Large 10 x 21 DOT Matrix LED Display
- Display Readout: Time, Distance, Heart Rate, Watts, RPM, Level, Speed And Calories
- Belt-driven Self Powered Hybrid Generator Drive
- 6 Preset Programs With 30 Resistance Levels
- Finger Touch Resistance Controls on Upper Arms
- Contact & Telemetric Heart Rate System
- 450 lbs max user weight
- 8 Bearing Linkage System
- 22 lb Fly Wheel
- 20" Natural Stride



CV-GR5

Commercial Recumbent Bike

Features

- Self powered drive system
- Hybrid generator resistance system
- 24 levels of resistance
- 22lb flywheel
- 6 preset programs with 20 levels
- Bottle and accessory holder
- Personal adjustable fan
- Durable powder coated frame
- 450lb. max user weight
- Walk-through frame for easy mounting
- 13 Level adjustable oversized seat
- Breathable mesh backrest
- Easy finger touch resistance control
- Adjustable foot straps



CV-GU5

Commercial Upright Bike

Features

- Self powered drive system
- Hybrid generator resistance system
- 24 levels of resistance
- 22lb flywheel
- Easy-glide seating with 13 positions
- 6 preset programs with 20 levels
- Bottle and accessory holder
- Personal adjustable fan
- Durable powder coated frame
- 450lb. max user weight
- Transport wheels for ease of transport
- 13 level adjustable oversized seat
- Breathable mesh backrest
- Easy finger touch resistance control
- Adjustable foot straps



CV-T22 Smart Treadmill



Features

- Motor: 5.5 HP Continuous Duty AC Motor
- Speed Range: 0.5 to 15.6 mph
- Elevation: 0%-20%
- Running Surface: 22" x 63"
- Step-up Height: 10"
- Rollers: 4"
- Steel Frame
- Non-skid Aluminum Side Rails
- Urethane Grips
- 500 lbs max user weight
- 20-Amp Dedicated & Separated Circuit From Breaker Box required
- Dedicated 120V/20amp circuit required
- Nema 3 Prong Plug

LED and Entertainment Consoles



Entertainment Consoles Include:

- Wifi enabled aps: Youtube, Netflix, Facebook, News, Sports, Amazon, Spotify & More!
- Google Internet Search Engine
- 14 Languages
- Virtual Reality Courses
- TV Option
- 19" HD Touchscreen

CV-S24Ei Elliptical



All Cardio Equipment Available w/ WI-FI Enable Entertainment Package

CV-E22 Smart Elliptical

Features

- Adjustable Fingertip Controls
- 40 Resistance Levels
- Adjustable Stride/Incline 1-10
- Large Step-up Plate
- Heart Rate Sensors
- Ability To Receive Digital Heart Rate Chest Strap And Heart Rate Monitor
- Powder Coated Steel Frame
- Non-skid Foot Pedals
- Urethane Grips
- Upper/Lower Body Workout
- Headphone Jack
- 400 lbs max user weight
- Self powered with optional 110 V Power for adjustable stride



CV-R22

Smart Recumbent Bike



CV-B22

Smart Upright Bike



All Cardio Equipment Available w/ WI-FI Enable Entertainment Package

CV-SM5

StepMill Full Commercial



Features

- Non-Slip, 8" Fixed Step, Revolving Stairs
- Speed Adjustable Floors Per Minute
- Ergonomically Designed Handrails
- Cup Holders And Accessory Tray
- USB Charging
- Polar Telemetry Heart Rate System
- Easy To Read LCD Display Console
- Display Readout: Calories, Levels 1-20, Floors Per Minute, Floors Climbed, Watts, METs And Workout Profile
- Quick Start Standard
- Fire Fighters WFI Test program
- CPAT Test Program
- 13 Total Workout Programs
- Max User Weight: 350Lbs. Min User Weight 125lbs.
- Minimum Ceiling Height Requirement – 10Ft.
- 20-Amp Dedicated & Separated Circuit From Breaker Box

CV-SEEG8925

Variable Elliptical – Stepper – Runner

Features

- Patent natural free stride movement
- LED Dot matrix display with 12 programs
- Self-Power system
- Contact heart rate
- Provides elliptical or stepping motion
- Lower rear point of entry
- Dual commercial bearings
- Multi-grip handlebars
- Fingertip resistance adjustments
- Durable upright post
- 1.5" pedal spacing
- Over-sized solid foot pedals
- Hardened 3pcs crankshaft
- Transport wheels
- Adjustable floor levelers
- Water bottle holder



CV-SRS860U

Training Cycle



77100

Indoor Exercise Bike



CV-AIRRAID-8AB

Airraid Bike



CV-1300

Club Rower



Features

- Chain Driven.
- 500LB Max User Weight.
- 55" Aluminum Monorail.
- Seat is 21" from the ground for easy entry and exit.
- Tracks distance, speed, pace, calories burned, watts and HR.
- Programmable Interval Functions (Work, Rest programs).
- Preset exercise modes: Normal, Target Distance, Target Time, Game, Tabata 20/10, Tabata 10/20, User Tabata 10/10.
- Set Distance time tracking.
- Teflon roller wheels with double sealed bearings.

CV-ROWERG

Concept II Rower



Features

- Overall Length : 96 in (244 cm)
- Width : 24 in (61 cm)
- Seat Height : With standard legs 14 in (36 cm) or with tall legs 20 in (51 cm)
- Monorail Length : 54 in (137 cm)
- Chain or Cord : Nickel-plated steel chain
- Monitor : PM5
- Power Requirement : Takes two D cell batteries. During your workout, the monitor draws power from the spinning flywheel to extend battery life.
- Maximum User Weight : 500 lb (227 kg)
- Monitor Arm : Rugged nylon. Pivots for storage and to adjust monitor height.
- Finish : Powder coat
- Color Scheme : Black
- Storage : Can be separated into two parts for easy storage
- Space Recommendations
- Assembled: 8 ft x 2 ft (244 cm x 61 cm)
- With Clearance for Use: 9 ft x 4 ft (274 cm x 122 cm)

BUILD PRIDE AND STRENGTH WITH PMX



BRAND YOUR WEIGHT ROOM



LASER CUT SCHOOL LOGO



CUSTOM LOGO BUMPERS



CUSTOM RACK LOGOS



CUSTOM LOGO UPHOLSTERY



CUSTOM INLAID PLATFORMS



CUSTOM LASER RACK LOGOS

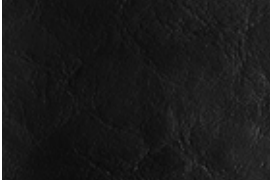

8540 : Black



6227 : Gray



6250 : Navy



6247 : Royal Blue



8612 : Light Blue



8404 : Dark Purple



8569 : Maroon



6244 : Forest Green



6227 : Kelly Green



6236 : Red



6233 : Orange



6230 : Bright Yellow



8606 : Camel

*Upholstery Colors Are All Standard
* Colors May Vary*



RAL9005 : Black



SPARKLE SILVER : Silver



RAL5003 : Navy Blue



RAL5005 : Royal Blue



RAL5015 : Light Blue



RAL5022 : Dark Purple

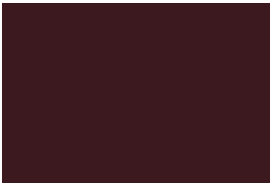

RAL3005 : Maroon



RAL6005 : Forest Green



RAL6029 : Kelly Green



RAL3001 : Red



RAL2017 : Orange



RAL1018 : Bright Yellow



RAL1024 : Gold

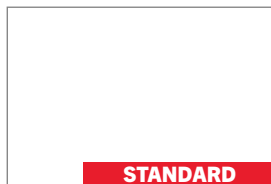

RAL9003 : White

*Powder Coat Gloss Finish
* Colors May Vary*



FOR ADDITIONAL INFORMATION:

Contact us at sales@promaxima.com or
call 713-667-9606 to speak to a representative now.

www.pmxstrength.com

5310 Ashbrook
Houston, Texas 77081